



CREATING A CLEANER, SAFER, HEALTHIER WORLD.



S30

MID-SIZED RIDER SWEEPER

- Provide excellent indoor and outdoor dust control with the SweepMax® Plus system
- Achieve consistent cleaning results in the toughest applications
- Ensure a healthy and safe environment with improved air quality
- Deliver easy operation and maintenance while running at peak performance

OPTIMIZED **SWEEPMAX® PLUS DUST CONTROL SYSTEM** OFFERS HIGHER CUSTOMER PRODUCTIVITY WITH **LESS DUST** GOING TO THE FILTER RESULTING IN **FEWER SHAKE BACKS** AND MORE TIME SPENT SWEEPING.



PATENTED 3-STAGE SWEEPMAX® PLUS DUST CONTROL SYSTEM
S30 is the only sweeper with cyclonics pre-filter stage of dust control.

Stage 1 – Perma-Filter™

- Tennant engineered design helps keep bulky debris, moisture and dirt in the hopper removing 90% of particulates from the air stream.

Stage 2 – SweepMax® Plus Cyclonics

- Longer filter life with exclusive cyclonics dust control that removes an additional 90% of dust particles from the air stream before reaching the filter.
- Cleaner air to filter means more time between filter shakebacks, and more time spent sweeping.

Stage 3 – Canister Nanofiber Filter

- MERV 15-rated, flame retardant Donaldson Ultra-Web® filter loads and shakes-back 70% more effectively, and cleaner air from filtering sub-micron dust particulates down to .5 microns at 99% efficiency.
- Excellent vacuum fan protection with 80 ft² (7.5 m²) surface area.

REDUCE YOUR COSTS AND MAXIMIZE PRODUCTIVITY

- In-hopper filter housing has shorter path for air to travel and shakes-back dust directly into the hopper, so dust is evacuated when the hopper is dumped.
- Quieter shakeback operation with in-hopper patented ShakeMax® 360 orbital shaker system.
- No-tool access with latches that remove the cyclones in seconds.
- Increase efficiency with monitoring from automatic notification and shaking (XP, X4).

EXCELLENT INDOOR AND OUTDOOR DUST CONTROL WITH THE **SWEEPMAX® PLUS CYCLONIC SYSTEM** HELPS REDUCE COST TO CLEAN, IMPROVE FACILITY IMAGE AND PROVIDE A SAFE ENVIRONMENT



THE S30 MID-SIZE RIDER SWEEPER DELIVERS EXCEPTIONAL DRY DUST CONTROL BENEFITS



REDUCE COST TO CLEAN

Increase productivity with the patented SweepMax® Plus cyclonic dry dust control system that reduces dust from reaching the filter, resulting in fewer shake backs and more time spent sweeping.



HEALTH & SAFETY

Reduce slip and fall potential by keeping floors clean of dust and debris with excellent dust control and debris pick-up.



ENHANCE FACILITY IMAGE

Protect your facility, assets and merchandise from getting dirty or damaged by capturing dust and debris with effective patented SweepMax® Plus dust control system.



EASY OPERATION & MAINTENANCE

Deliver consistent sweeping results with this easy-to-operate and maintain sweeper which runs at peak performance year after year with its quality engineering.

INSIDE THE S30



Exclusive color coded brush wear indicator for correct brush position



Optional 1-Step™ start button simplifies operator training with controls that enable sweeping systems to be activated with a single green button

Simple “All-Levers Forward” control system delivers consistent sweeping results and simplifies operation

Exclusive cab forward design for reduced operator fatigue and increased comfort

Rounded corner design improves turn-off from walls or racking to minimize damage

II-Speed™ sweep system increases the speed of the main brush, side brush, and vacuum fan by 15%

Standard Thermo-Sentry™ hopper temperature sensor

Heavy-gauge steel machine frame designed for long-term structural reliability and strength

Standard right-side sweeping brush, and optional dual side brushes for increased productivity

SweepMax® Plus provides cyconic filtration and dry dust control for sweeping all floor surfaces

Retractable, spring-loaded flap recirculates debris for improved sweeping results

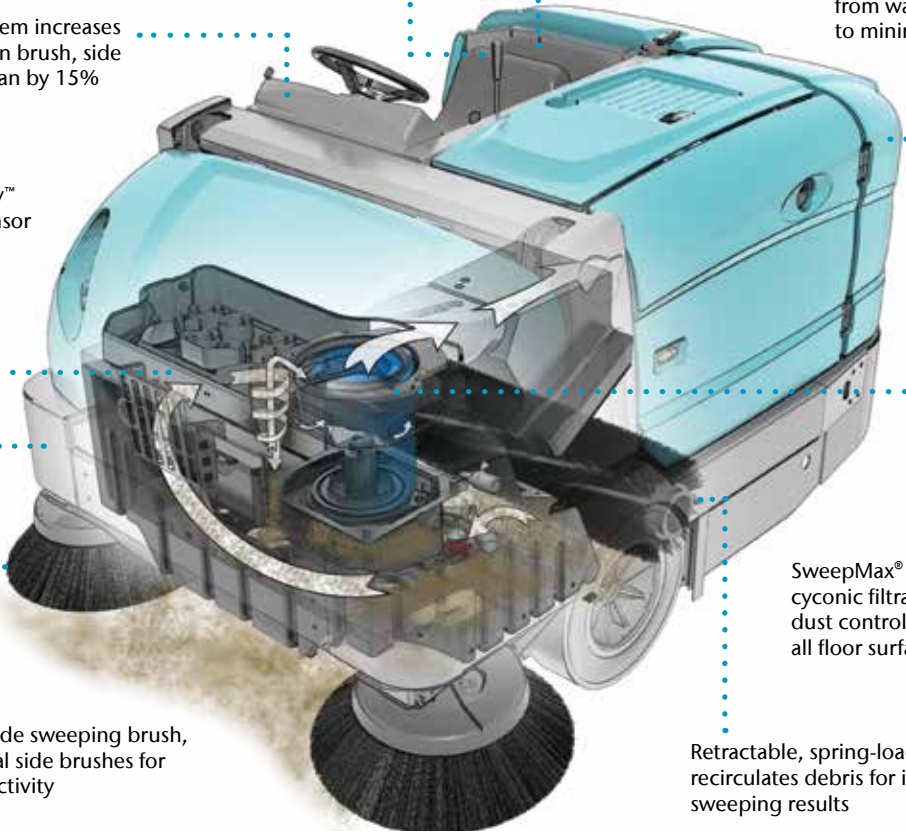

Reduce downtime and operator fatigue with easy no-tool brush removal and change, aided by the self-guiding 8-spline drive and idler hub

Effective one-pass sweeping with a retractable, spring-loaded re-circulation flap near the rear skirt, recirculating any debris that may escape over the main brush

Increased sweeping results with a main brush that is only 2 in (51 mm) wider than the hopper opening, as compared to some competitors with brushes wider than their hopper openings



KEY S30 SWEEPER FEATURES TO HELP MAXIMIZE PRODUCTIVITY, REDUCE COSTS, INCREASE SAFETY

- **Patented SweepMax® Plus cyclonic dry dust** separation technology removes an additional 90% of dirt and dust particles before reaching the filter
- **Donaldson Ultra-Web® MERV 15 nanofiber filter** loads and shakes back more effectively
- **8 spline brush drive** with deep 6.5 in (165 mm) brush engagement delivers consistent brush pressure plus end-to-end brush rotation for one pass sweeping
- **EasyOpen™ service access** with onboard diagnostics
- **Large capacity hydraulic oil tank** and triple accessory pumps
- **Dumps at any height** from ground level to 60 in / 1525 mm and reaches up to 30 in / 760 mm into a standard dumpster
- **II-Speed™ sweeping** increases main brush, side brush, and vacuum fan speeds up to 15%
- Easy-to-set **color-coded brush wear indicator** for quick brush pressure settings
- **Patented ShakeMax® 360** orbital shaker in-hopper delivers 70% more effective shakeback and quieter operation
- **No-tool access** to the cyclonic system provides easy clean-outs and minimizes maintenance time
- **Optional FOPS Certified Cab** provides protection from falling objects
- **Optional ANSI tested Overhead Guard** protects the operator from objects falling directly above
- Standard Configurations:
 - Base 3-wheel, plastic hopper, mechanical controls, and standard seat
 - S30 XP 3-wheel, plastic hopper, electronic controls, deluxe seat
 - S30 X4 (Diesel Only) 4-wheel, plastic hopper, electronic controls, deluxe seat



Achieve outstanding results in diverse environments with dual side brushes which, combined with a large 14 ft³ / 395 L Duramer™ hopper, allow you to sweep up to 80 in / 2,030 mm in a single pass.

Travel between work sites safely and quickly with the S30 X4 configuration that travels up to 15 mph / 24 km/h on a stable 4 wheel platform with comfortable suspension.

Operate safely and comfortably in even the most severe environments, with an optional FOPS certified (ISO 3449) pressurized cabin, available with heat and air conditioning.



- Reduce rework, labor and safety costs by using only TennantTrue parts and service.
- Ensure optimal cleaning performance by selecting a TennantTrue Service program provided by a network of over 400 factory-trained Tennant service representatives.
- Improve uptime by leveraging TennantTrue parts and service.
- Simplify budgeting by bundling TennantTrue service plans, including parts, into the purchase or financing of your machine.

Lease. Pre-Owned. Rent. Tennant has flexible options that get you the machines you need, however you need them.

S30 MID-SIZE RIDER SWEEPER

SWEEPING SYSTEM

Cleaning path	
Single side brush	62.5 in / 1,588 mm
Dual side brush	80 in / 2,032 mm
Main brush	
Main brush length (<i>tubular</i>)	45 in / 1,145 mm
Main brush lift	Mechanical or Hydraulic
Main brush change	No-tool
Side broom	
Side broom diameter	26 in / 660 mm
Debris hopper	
Volume capacity	14 ft ³ / 395 L
Weight capacity (<i>plastic</i>)	1,080 lb / 490 kg
Weight capacity (<i>steel</i>)	1,200 lb / 545 kg
Dump height (<i>variable to</i>)	60 in / 1,525 mm
Dump reach	30 in / 760 mm

DUST CONTROL SYSTEM

Filter system (<i>triple stage</i>)	
Stage 1	Perma-filter™
Stage 2	SweeperMax® Plus Cyclonic pre-filter
Stage 3	Donaldson Ultra-Web® Nanofiber canister filter
Filter area	80 ft ² / 7.4 m ²
Dust filtration (<i>seasoned filter</i>)	0.5 microns @ 99% efficiency
Shaker mechanism	ShakeMax® 360 Orbital Shaker
Vacuum fan speed	
Normal sweeping mode	4,600 rpm
Litter sweeping mode	5,500 rpm
Vacuum diameter	11 in / 280 mm

PROPELLING SYSTEM

Propel speed forward (<i>variable to</i>)	
3-wheel (Gas/LP)	8 mph / 13 km/h
X4 (Diesel)	15 mph / 24 km/h
Propel speed reverse (<i>variable to</i>)	3.0 mph / 5.0 km/h
Engine-gasoline/LPG	
Gross Intermittent Power*	60.0 hp / 44.7 kW @3000 rpm
Tennant Governed Power	50.0 hp / 37.3 kW @2300 rpm
Engine-diesel	
Gross Intermittent Power*	24.8 hp / 18.5 kW @2300 rpm
Tennant Governed Power	24.8 hp / 18.5 kW @2300 rpm
Gradeability - full hopper	
3-wheel (Gas/LP)	10° / 18%
X4 (Diesel)	6° / 10.5%
Gradeability - empty hopper	
3-wheel (Gas/LP)	14° / 25%
X4 (Diesel)	9° / 16%
Ground clearance	4 in / 100 mm

MACHINE SPECIFICATIONS

Length	93 in / 2,360 mm
Width	62.5 in / 1,590 mm
Height	
With overhead guard	82.5 in / 2,095 mm
Without overhead guard	58 in / 1,475 mm
Weight (net, 3-wheel)	3,570 lb / 1,620 kg
Minimum aisle turn	113 in / 2,870 mm

WARRANTY

See your local representative for warranty information.

*Per SAE J1995

*Specifications based on standard machine configurations, no options.
Specifications subject to change without notice.*

SEEING IS BELIEVING

For a demonstration or additional information,
call +1.800.553.8033 or email info@tennantco.com