

JLG MODEL E300 Series

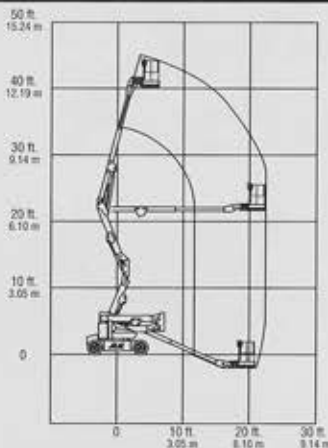

**E300AJ
E300AJP**

JLG MODEL E400 Series



**E400A
E400AJP** **E400A Narrow
E400AJP Narrow**

JLG MODEL E450 Series

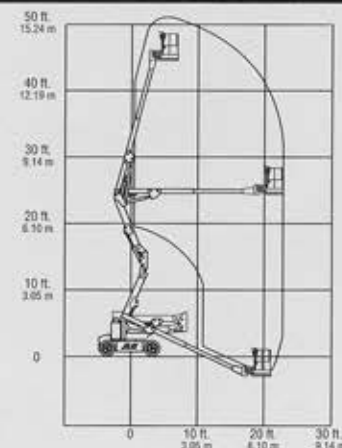

E450A **E450AJ**

Reach Specifications

Platform Height	30 ft (9.14 m)	40 ft (12.19 m)	40 ft (12.19 m)	45 ft (13.72 m)	45 ft (13.72 m)
Horizontal Outreach	—	21 ft 2 in. (6.41 m)	21 ft 2 in. (6.41 m)	23 ft 1 in. (7.04 m)	—
with Jib	20 ft (6.1 m)	—	—	—	23 ft 9 in. (7.24 m)
with JibPLUS	20 ft 6 in. (6.25 m)	22 ft 5 in. (6.83 m)	22 ft 5 in. (6.83 m)	—	—
Up and Over Height	13 ft 1 in. (3.99 m)	21 ft 6 in. (6.55 m)	21 ft 6 in. (6.55 m)	24 ft 7 in. (7.49 m)	25 ft 3 in. (7.7 m)
Swing	360 Degrees Non-Continuous	360 Degrees Non-Continuous	360 Degrees Non-Continuous	360 Degrees Non-Continuous	360 Degrees Non-Continuous
Platform Capacity	500 lb (227 kg)	500 lb (227 kg)	500 lb (227 kg)	500 lb (227 kg)	500 lb (227 kg)
Platform Rotator	180 Degrees Hydraulic	180 Degrees Hydraulic	180 Degrees Hydraulic	180 Degrees Hydraulic	180 Degrees Hydraulic
Jib (range of articulation)	144 Degrees (+84, -60) Vertical	—	141 Degrees (+86, -55) Vertical	—	141 Degrees (+86, -55) Vertical
(JibPLUS)	180 Degrees Horizontal	180 Degrees Horizontal	180 Degrees Horizontal	—	—
	144 Degrees (+84, -60) Vertical	144 Degrees (+84, -60) Vertical	144 Degrees (+84, -60) Vertical	—	—

Dimensional Data

Platform Size	30 x 48 in. (0.76 x 1.22 m)	30 x 48 in. (0.76 x 1.22 m)	30 x 48 in. (0.76 x 1.22 m)	30 x 60 in. (0.76 x 1.52 m)	30 x 60 in. (0.76 x 1.52 m)
Overall Width	4 ft (1.22 m)	5 ft 9 in. (1.75 m)	4 ft 11 in. (1.5 m)	5 ft 9 in. (1.75 m)	5 ft 9 in. (1.75 m)
Tailswing	Zero	Zero	4 in. (10 cm)	Zero	Zero
Stowed Height	6 ft 7 in. (2.00 m)	6 ft 7 in. (2.00 m)	6 ft 5.75 in. (1.97 m)	6 ft 6 in. (1.98 m)	6 ft 7 in. (2.01 m)
Stowed Length	—	18 ft 1 in. (5.5 m)	18 ft 1 in. (5.5 m)	19 ft 1 in. (5.82 m)	—
with Jib	18 ft (5.49 m)	—	—	—	21 ft 2 in. (6.45 m)
with JibPLUS	18 ft 8 in. (5.70 m)	22 ft (6.7 m)	22 ft (6.7 m)	—	—
Wheelbase	5 ft 5 in. (1.65 m)	6 ft 7 in. (2.0 m)	6 ft 7 in. (2.0 m)	6 ft 7 in. (2.0 m)	6 ft 7 in. (2.0 m)
Ground Clearance	4 in. (10 cm)	8.5 in. (22 cm)	5 in. (13 cm)	8.5 in. (22 cm)	8.5 in. (22 cm)
Gross Vehicle Weight	—	12,100 lb (5,488 kg)	13,100 lb (5,942 kg)	12,600 lb (5,715 kg)	—
with Jib	14,600 lb (6,623 kg)	—	—	—	14,400 lb (6,532 kg)
with JibPLUS	15,100 lb (6,850 kg)	13,700 lb (6,214 kg)	14,900 lb (6,759 kg)	—	—
Ground Bearing Pressure	121 psi (8.47 kg/cm ²)	80 psi (5.6 kg/cm ²)	95 psi (6.7 kg/cm ²)	64 psi (4.48 kg/cm ²)	75 psi (5.25 kg/cm ²)

Chassis

Drive Speed	3.0 mph (4.8 kph)	3.2 mph (5.2 kph)	3.0 mph (4.8 kph)	3.2 mph (5.2 kph)	3.2 mph (5.2 kph)
Gradeability	25%	30%	30%	30%	30%
Turning Radius (Inside)	5 ft (1.52 m)	2 ft (61 cm)	2 ft 10 in. (86 cm)	2 ft (61 cm)	2 ft (61 cm)
Turning Radius (Outside)	10 ft 2 in. (3.1 m)	10 ft 4 in. (3.15 m)	10 ft 4 in. (3.15 m)	10 ft 4 in. (3.15 m)	10 ft 4 in. (3.15 m)
Tire Size/Type	7.5 x 12 Non-Marking	240/55-17.5 pneumatic	240/55-17.5 pneumatic	240/55-17.5 pneumatic	240/55-17.5 pneumatic
Tire Size/Type Narrow (front)	—	—	22 x 6 x 17.5 Non-Marking	—	—
Tire Size/Type Narrow (back)	—	—	22 x 7 x 12 Non-Marking	—	—

Power Source

Electrical System	48V DC	48V DC	48V DC	48V DC	48V DC
Batteries	8 x 6V 370 amp/hr	8 x 6V 370 amp/hr	8 x 6V 370 amp/hr	8 x 6V 370 amp/hr	8 x 6V 370 amp/hr
Drive Motors	Dual Electric Traction	Dual Electric Traction	Dual Electric Traction	Dual Electric Traction	Dual Electric Traction
Brakes	Automatic Spring Applied Multiple	Automatic Spring Applied Multiple	Automatic Spring Applied Multiple	Automatic Spring Applied Multiple	Automatic Spring Applied Multiple
Hydraulic Motor/Pump	Permanent Magnet Motor/Gear Pump	Permanent Magnet Motor/Gear Pump	Permanent Magnet Motor/Gear Pump	Permanent Magnet Motor/Gear Pump	Permanent Magnet Motor/Gear Pump
Hydraulic Reservoir	3 gal. (11.4 L)	4 gal. (15.2 L)	4 gal. (15.2 L)	4 gal. (15.2 L)	4 gal. (15.2 L)
Generator Set (Multi-Power Options)	—	Fully Automatic, 45 Amp Yanmar 6 hp Air-Cooled Engine	Fully Automatic, 45 Amp Yanmar 6 hp Air-Cooled Engine	Fully Automatic, 45 Amp Yanmar 6 hp Air-Cooled Engine	Fully Automatic, 45 Amp Yanmar 6 hp Air-Cooled Engine
Engine Fuel Tank	—	4 gal. (15.2 L)	4 gal. (15.2 L)	4 gal. (15.2 L)	4 gal. (15.2 L)

*Certain options or country standards will increase weight.

The JLG "1 & 5" Warranty

JLG Industries, Inc. backs its products with its exclusive "1 & 5" Warranty. We provide coverage on all products for one (1) full year, and cover all specified major structural components for five (5) years. Due to continuous product improvements, we reserve the right to make specification and/or equipment changes without prior notification. This machine meets or exceeds applicable OSHA Regulations in 29 CFR 1910.67, 29 CFR 1926.453, ANSI A92.5-1992, and CSA Standard B354.4-02, as originally manufactured for intended applications.

JLG Industries, Inc.

1 JLG Drive, McConnellsburg, PA 17233-9533
Telephone 717-485-5161 Toll-free in US 877-JLG-LIFT
Fax 717-485-6417
www.jlg.com

Printed in USA
FORM NO.: S5EB00MS-1202-10M
PART NO.: 3131119
R070502

