

# COMPACT 2032E/2632E

## The Haulotte® advantages

- Stowed height allows passage through standard doorways
- 32 in width allows operation in the most congested areas
- 7 ft 10 in outside turning radius ensures excellent manoeuvrability
- Pot Hole protection and load limiter in cage ensures maximum safety
- Driveable at full height
- Robust, reliable and easy to maintain design

## STANDARD FEATURES

- Folding guardrails (compact 2632E)
- Non marking tires
- 3 ft platform extension
- Tilt alarm
- Drive speeds
- 2 front wheel drive and steer
- Free wheeling device
- 24 V - 4 x 6 V batteries
- 30 amp battery charger
- Battery charge indicator
- Hourmeter
- Horn in platform
- Towing hooks / lifting eyes
- Emergency lowering system
- Safety harness anchor points
- 115 V - 15 A outlet

## OPTIONS & ACCESSORIES

- Motion alarm
- 59 in extension from upper control box
- Working light
- Flashing light

# Electric scissor lifts

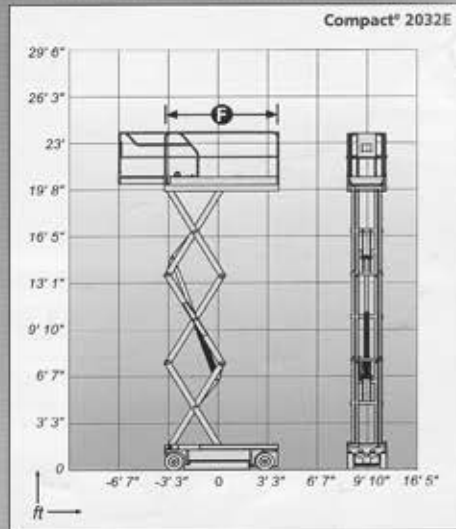

## SPECIFICATIONS

	Compact 2032E	Compact 2632E
Working height	26 ft 1 in	32 ft 10 in
Platform height	20 ft 3 in	26 ft 3 in
Driveable at full height	20 ft 3 in	26 ft 3 in
Platform capacity	770 lb	507 lb
<b>A</b> Stowed length		91 in
with access steps		98 in
<b>B</b> Width		32 in
<b>C</b> Stowed height	78,4 in	7 ft 1 in
Transport height	44 in	52,3 in
<b>D</b> Wheelbase		6 ft 1 in
<b>E</b> Ground clearance		4,9 in
with deployed Pot Hole		1 in
<b>F</b> x <b>G</b> Platform size		91 in x 32 in
Extension : Size		3 ft
Extension : Capacity	330 lb	265 lb
Drive speed	0,6 mph - 1,8 mph	
Inside turning radius	0	13 in
Outside turning radius	7 ft 10 in	
Lift / lower speed (sec.)	37 / 41 sec	46 / 51 sec.
Gradeability	25%	23%
Tilt Alarm	2°	
Controls	Proportional	
Batteries (amp/h)	180	180
Tires (solid / non marking)	15 x 5 x 2 in	
Hydraulic tank	7 gal	
Weight	3,815 lb	4,762 lb



D I S T R I B U T E D B Y

