

# HA 46 JRT HA 51 JRT

## The Haulotte® advantages

- 52 ft and 57 ft working heights
- Hydraulic differential lock and 16 in ground clearance for improved rough terrain capability
- Gradeability up to 50%
- Continuous 360° turntable rotation
- 45 sec. lift speed to full height
- Full proportional controls and simultaneous boom functions improve productivity
- Improved working area through a positive/negative articulating fly jib with 140° movement
- Zero tailswing
- 180° hydraulic platform rotation
- Improved design for travel / transport (HA 46 JRT: 17 ft 3 in transport length)
- Robust, reliable and easy to maintain design

## STANDARD FEATURES

- 4 wheel drive and steer
- Rotating engine tray for easier maintenance
- Fuel tank 16 gal
- Tilt alarm
- 12 V battery / electrical control system
- Electric emergency group in cage
- Free wheeling device
- Hourmeter
- Slewing block pin
- Towing hooks / lifting eyes

## OPTIONS & ACCESSORIES

- Dual Gaz / Fuel engine (GM 1.6 L / 23 kW)
- On-board generator 3.3 kW
- 230 V/115 V - 16 A power line in cage
- 8 ft basket
- Travel alarm
- Rotating beacon
- Working light
- Catalytic purifier
- Encoded starting device
- Biodegradable hydraulic oil

## Articulated boom

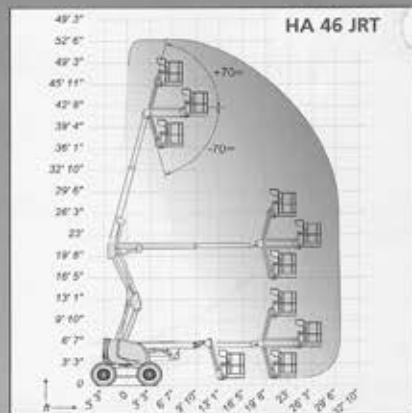
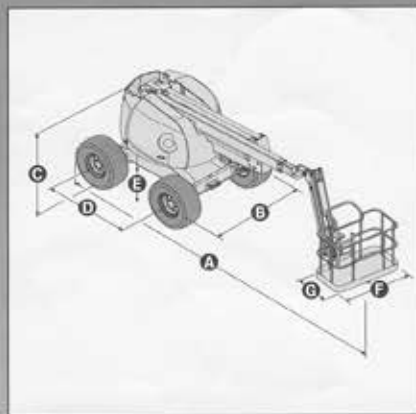

## SPECIFICATIONS

	HA 46 JRT	HA 51 JRT
Working height	52 ft	56 ft 2 in
Platform height	46 ft	50 ft 2 in
Maximum outreach	29 ft 1 in	34 ft 9 in
Up and over clearance	21 ft 8 in	21 ft 8 in
Platform capacity	507 lb	507 lb
Fly jib range of motion	140° (+70° / -70°)	
<b>A</b> length	22 ft 10 in	25 ft
<b>B</b> width	7 ft 7 in	7 ft 7 in
<b>C</b> stowed height	7 ft 3 in	7 ft 3 in
<b>D</b> wheelbase	6 ft 7 in	6 ft 7 in
<b>E</b> ground clearance	16 in	16 in
<b>F</b> x <b>G</b> platform size	71 in x 32 in	71 in x 32 in
Travel / transport length	17 ft 3 in	19 ft 4 in
Travel / transport height	7 ft 3 in	7 ft 3 in
Tailswing	0	0
Drive speed	0.9 - 3.7 mph	
Outside turning radius	13 ft 1 in	13 ft 1 in
Inside turning radius	6 ft 3 in	6 ft 3 in
Turntable rotation (continuous)	360°	360°
Hydraulic platform rotation	180°	180°
Engine	Deutz Diesel 38 CV (38 HP) - 28 kW	
Gradeability	50%	
Tyres (foam filled and wide)	385 / 65 - 22.5	
Hydraulic tank	22 gal	22 gal
Fuel tank	16 gal	16 gal

ANSI/SIA A92.6-1999 compliance

DISTRIBUTED BY



# Haulotte®

HAULOTTE US INC • 7135 STANDARD DRIVE - HANOVER MD 21076 - USA

PHONE : +1 410 712 4403 • FAX : +1 410 712 4419 • MAIN TOLL FREE : +1 877-HAULOTTE • SERVICE TOLL FREE : +1 877-HAULOT-S • Web : <http://www.haulotte.com>  
PINGUELY-HAULOTTE GROUP